

THIS DRAWING CONTAINS INFORMATION THAT IS PROPRIETARY TO J.S.T. AND SHOULD NOT BE USED WITHOUT WRITTEN PERMISSION.

A B C D E F G H

1 2 3 4 5 6 7 8 9 10 11 12

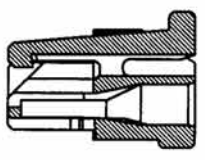
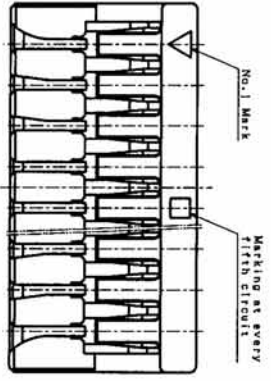
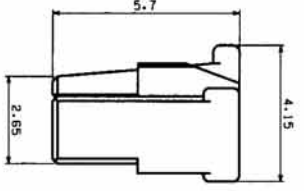
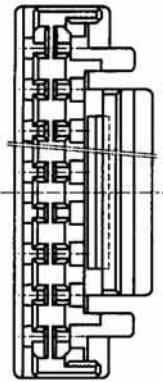
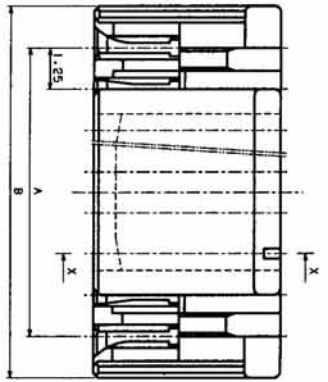
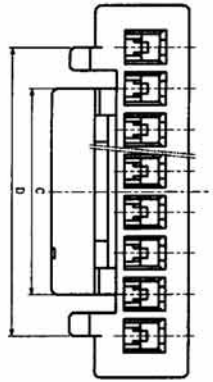

Circuit	Dimensions			
	A	B	C	D
2	1.25	3.75	2.35	-
3	2.50	5.00	3.20	-
4	3.75	6.25	4.25	-
5	5.00	7.50	4.25	6.75
6	6.25	8.75	6.25	8.75
7	7.50	10.00	6.25	8.75
8	8.75	11.25	6.25	8.75
9	10.00	12.50	6.25	8.75
10	11.25	13.75	8.20	10.70
11	12.50	15.00	8.20	10.70
12	13.75	16.25	8.20	10.70
13	15.00	17.50	8.20	10.70
14	16.25	18.75	8.20	10.70
15	17.50	20.00	8.20	10.70

NOTE  
 1. Unless otherwise specified, tolerances are 0.05(±0.15), 0.10(±0.2), 0.20(±0.3)

REV	DESCRIPTION	DATE	DESIGNED																								
1																											
<table border="1"> <tr> <td>No.</td> <td>PART NAME</td> <td>PRT</td> <td>MATERIAL</td> <td>SURFACE FINISH</td> <td>REMARKS</td> </tr> <tr> <td>A2</td> <td>METRIC 10:1</td> <td></td> <td>DEC. 20, 2004</td> <td></td> <td></td> </tr> <tr> <td>APPROVED</td> <td>DESIGNED</td> <td>DRAWN</td> <td>CHECKED</td> <td></td> <td></td> </tr> <tr> <td>T.N</td> <td>S.S</td> <td>T.T</td> <td>M.Y</td> <td></td> <td></td> </tr> </table>				No.	PART NAME	PRT	MATERIAL	SURFACE FINISH	REMARKS	A2	METRIC 10:1		DEC. 20, 2004			APPROVED	DESIGNED	DRAWN	CHECKED			T.N	S.S	T.T	M.Y		
No.	PART NAME	PRT	MATERIAL	SURFACE FINISH	REMARKS																						
A2	METRIC 10:1		DEC. 20, 2004																								
APPROVED	DESIGNED	DRAWN	CHECKED																								
T.N	S.S	T.T	M.Y																								
<table border="1"> <tr> <td>HOUSING</td> <td>PRT</td> <td>MATERIAL</td> <td>SURFACE FINISH</td> <td>REMARKS</td> </tr> <tr> <td></td> <td></td> <td></td> <td></td> <td></td> </tr> </table>				HOUSING	PRT	MATERIAL	SURFACE FINISH	REMARKS																			
HOUSING	PRT	MATERIAL	SURFACE FINISH	REMARKS																							
<table border="1"> <tr> <td>SIZE</td> <td>UNIT</td> <td>SCALE</td> <td>PROJECTION</td> <td>DATE</td> </tr> <tr> <td>A2</td> <td>METRIC</td> <td>10:1</td> <td>1</td> <td>DEC. 20, 2004</td> </tr> </table>				SIZE	UNIT	SCALE	PROJECTION	DATE	A2	METRIC	10:1	1	DEC. 20, 2004														
SIZE	UNIT	SCALE	PROJECTION	DATE																							
A2	METRIC	10:1	1	DEC. 20, 2004																							
<table border="1"> <tr> <td>APPROVED</td> <td>DESIGNED</td> <td>DRAWN</td> <td>CHECKED</td> </tr> <tr> <td>T.N</td> <td>S.S</td> <td>T.T</td> <td>M.Y</td> </tr> </table>				APPROVED	DESIGNED	DRAWN	CHECKED	T.N	S.S	T.T	M.Y																
APPROVED	DESIGNED	DRAWN	CHECKED																								
T.N	S.S	T.T	M.Y																								
<table border="1"> <tr> <td>ORDERING PART NO.</td> <td>QUANTITY</td> <td>REMARKS</td> </tr> <tr> <td>KRD-3297B-1</td> <td></td> <td></td> </tr> </table>				ORDERING PART NO.	QUANTITY	REMARKS	KRD-3297B-1																				
ORDERING PART NO.	QUANTITY	REMARKS																									
KRD-3297B-1																											

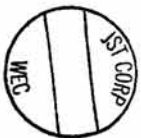

JST J.S.T. MFG. CO., LTD.

RD

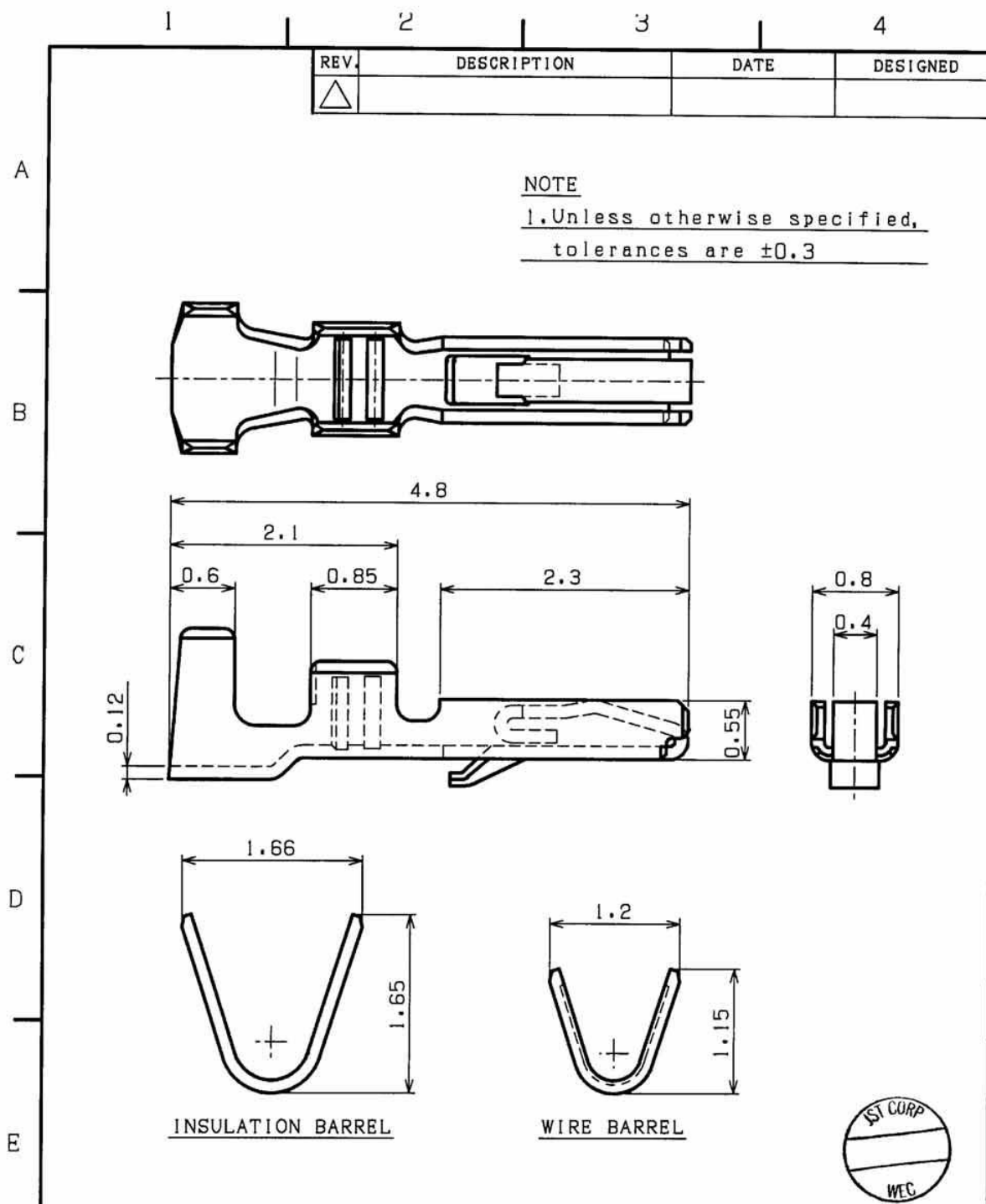

REV.	DESCRIPTION	DATE	DESIGNED
△			

**NOTE**  
 1. Unless otherwise specified,  
 tolerances are  $\pm 0.3$

CONTACT		PHOSPHOR BRONZE		TIN-PLATED		t0.2	
No.	PART NAME	MATERIAL		SURFACE FINISH		REMARKS	
SIZE	UNIT	SCALE	PROJECTION	DATE	CUSTOMER		
A4	METRIC	20:1		APR. 2.2004	GH CONNECTOR		
APPROVED	CHECKED	DESIGNED	DRAWN	SERIES NAME	PART No.		
T.N	S.S	T.T	M.Y	GH CONNECTOR	SSH L-002T-P0.2		
<b>JST</b> J.S.T.MFG.CO., LTD.				DRAWING No.	KRD-32938	RD	

